

ADDENDUM NO. 1  
DATED MAY 27, 2010

CONTRACT DOCUMENTS AND TECHNICAL SPECIFICATIONS  
FOR THE LAKESIDE DRIVE EXTENSION SANITARY SEWER IMPROVEMENTS

CITY OF SEABROOK PROJECT NO. 2010-04

The attention of all prospective Bidders is directed to the following modifications to Drawings, Specifications, and Contract Documents for the above-referenced project. The information contained in this Addendum supersedes information contained in the Drawings, Specifications, and Contract Documents to the extent indicated. All information contained in the Drawings, Specifications, and Contract Documents remains in full force and effect unless specifically modified herein.

CONTRACT DOCUMENTS:

Bid Form – A revised bid form is attached. The changes to the form are:

- 1) An extra work item has been included for wet trench construction. The wet trench construction should not be used as a substitute for dewatering, it should be used only as advised by the City.

DRAWINGS:

- 1) An 8 ½" x 11" detail for the wet stable trench construction is attached for reference when bidding and construction using wet trench construction.

CLARIFICATIONS:

This section is intended to clarify or provide additional information and does not supersede the Contract Documents, Technical Specifications, and Construction Plans. This section does not try to report the complete notes of the Pre-Bid Conference.

A pre-bid conference was held Wednesday, May 26, 2010 at 2:00 p.m. at the City of Seabrook City Hall. A list of attendees is available at [www.cobbfendley.com](http://www.cobbfendley.com). A brief summary of the project was presented, followed by a question-and-answer session.

- 1) The City will provide a full time inspector for the duration of the project. The City will pay the fee for the inspector.
- 2) The Contractor will be required to provide a lab approved by the City for materials testing. The lab should be submitted during the submittals process after the bid is awarded. The extent of the lab testing is at the discretion of the

Contractor for bidding purposes. The inspector will advise the City if additional testing is required due to poor compaction, and it will be at the cost to the Contractor.

- 3) The City will pump down the lift station at Repsdorph for the Contractor prior to the tie-in. All work associated with the lift stations should be coordinated with the City prior to construction.
- 4) Inflow protectors on the manholes should be plastic.
- 5) No burning of clearing debris will be allowed in the city limits.
- 6) The City will require cement stabilized sand in locations where the pipe will be under the proposed roadway.

Direct any questions concerning this Addendum to Cobb, Fendley, and Associates to either Mr. Brad Matlock or Ms. Amy Stonaker at (713) 462-3242.

END OF ADDENDUM NO. 1

APPROVED FOR ISSUE:

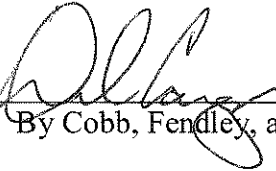

By Cobb, Fendley, and Associates, Inc.

END OF DOCUMENT

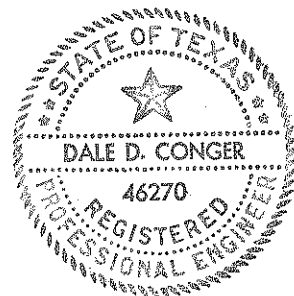

Section 00300

BID FORM

TO: City of Seabrook  
City Hall  
1700 First Street  
Seabrook, Texas 77586

PROJECT: Lakeside Drive Connection Sanitary Improvements  
PROJECT NO.: 2010-04

BIDDER: \_\_\_\_\_  
(Print or type full name of proprietorship, partnership, corporation, or joint venture.)

1. The undersigned bidder proposes and agrees, if this Bid is accepted, to enter into an Agreement with OWNER in the form included in the Contract Documents to perform and furnish all Work as specified or indicated in the Contract Documents for the Contract Price and within the Contract Time indicated in this Bid and in accordance with the other terms and conditions of the Contract Documents.
2. BIDDER accepts all of the terms and conditions of the Advertisement or Invitation to Bid and Instructions to Bidders, including without limitation those dealing with the deposition of Bid Security. This Bid will remain subject to acceptance for 60 calendar days after the day of Bid opening. BIDDER will sign and submit the Agreement with the Bonds and other documents required by the Bidding Requirements within 15 calendar days after the date of OWNER'S Notice of Award.
3. In submitting this Bid, BIDDER represents, as more fully set forth in the Agreement, that:
  - A. BIDDER has examined copies of all the Bidding Documents and of the following Addenda (receipt of all which is hereby acknowledged):

Date	Number
_____	_____
_____	_____
_____	_____

- B. BIDDER has familiarized itself with the nature and extent of the Contract Documents, Work, site, locality, and all local conditions and Laws and Regulations that in any manner may affect cost, progress, performance, or furnishing of the Work.
- C. BIDDER has studied carefully all reports and drawings of subsurface conditions and drawings of physical conditions as provided in Paragraph 4.02 of the General Conditions,

- and accepts the determination of the technical data contained in such reports and drawings upon which BIDDER is entitled to rely.
- D. BIDDER has obtained and carefully studied (or assumes responsibility for obtaining and carefully studying) all such examinations, investigations, explorations, tests, and studies (in addition to or to supplement those referred to in C above) which pertain to the subsurface or physical conditions at the site or otherwise may affect the cost, progress, performance, or furnishing of the Work as BIDDER considers necessary for the performance or furnishing of the Work at the Contract Price, within the Contract Time, and in accordance with the other terms and conditions of the Contract Documents, including specifically the provisions of Paragraph 4.02 of the General Conditions; and no additional examinations, investigations, explorations, tests, reports, or similar information or data are or will be required by BIDDER for such purposes.
- E. BIDDER has reviewed and checked all information and data shown or indicated on the Contract Documents with respect to existing underground facilities at or contiguous to the site and assumes responsibility for the accurate location of said underground facilities. No additional examinations, investigations, explorations, tests, reports, or similar information or data in respect to said underground facilities are or will be required by BIDDER in order to perform and furnish the Work at the Contract Price, within the Contract Time, and in accordance with the other terms and conditions of the Contract Documents, including specifically the provisions of Paragraph 4.03 of the General Conditions.
- F. BIDDER has correlated the results of all such observations, examinations, investigations, explorations, tests, reports, and studies with the terms and conditions of the Contract Documents.
- G. BIDDER has given ENGINEER written notice of all conflicts, errors, or discrepancies that it has discovered in the Contract Documents, and the written resolution thereof by ENGINEER is acceptable to BIDDER.
- H. This Bid is genuine and not made in the interest of or on behalf of any undisclosed person, firm, or corporation, and is not submitted in conformity with any Agreement or rules of any group, association, organization, or corporation; BIDDER has not directly or indirectly induced or solicited any other BIDDER to submit a false or sham Bid; BIDDER has not solicited or induced any person, firm, or corporation to refrain from bidding; and BIDDER has not sought by collusion to obtain for itself any advantage over any other BIDDER or over OWNER.
4. BIDDER will complete the Work for the following price: (Note: Bid item is for work complete in place). These prices are to cover all expenses incurred in performing the work required under the Contract Documents, including related work that may not be specifically mentioned.

**A. BASE BID ITEMS**

Item No.	Item Description	Unit	Quantity	Unit Price	Extended Price
1	Mobilization (No Greater than 5% of Total Bid)	LS	1		
2	Stabilized Construction Entrance, Install and Remove	LS	1		
3	Clearing and Grubbing	LS	1		
4	Demolition of Existing Lift Station on Lakeside Drive, Includes removal of lift station, filling in sump, cutting, plugging, removal of existing force main and gravity main, and fence removal, Complete	LS	1		
5	Trench Safety System	LF	1275		
6	12" Sanitary Sewer, PVC, SDR-26 Open Cut, Complete in Place	LF	1275		
7	Sanitary Sewer Manholes (Up to 8' Depth), Includes installation of inflow protectors and protective coatings of entire manhole interior, Complete in Place	EA	7		
8	Extra Depth for Manholes	VF	43		
9	Connect 12-inch Sanitary Sewer Gravity Line to Existing Repsdorff Lift Station, Includes coring into 9-inch thick wall and sealing with TYLOX HKT rubber gasket, Complete	LS	1		
10	Connect 12-inch Sanitary Sewer Gravity Line to Existing Sanitary Sewer Manhole, Includes coring into manhole and sealing with TYLOX HKT rubber gasket, Complete	LS	1		
11	Dewatering	LF	1275	\$25	\$31,875
12	Hydromulch Seeding	AC	0.5		

**TOTAL BASE BID PRICE**

\$ \_\_\_\_\_

Item No.	Item Description	Unit	Quantity	Unit Price	Extended Price
<b>Extra Work Items</b>					
1	Wet Stable Trench Construction	LF	100		

**TOTAL EXTRA WORK ITEMS PRICE** \$ \_\_\_\_\_

**B. TOTAL BID PRICE** \$ \_\_\_\_\_

**C. DEDUCTIONS FROM BID ITEMS**

BIDDER acknowledges that OWNER has a maximum funding limitation and that OWNER may adjust the total quantity of the items listed above to conform to that limitation. Reducing the quantity of items listed in this BID shall not invoke the provisions of Paragraph 11.03D.1 of the General Conditions unless such reduction exceeds 20% of any individual item.

5. BIDDER agrees that the Work will be substantially complete and completed and ready for final payment in accordance with Paragraph 14.07 of the General Conditions on or before the dates or within the number of calendar days indicated in the Agreement.
6. The following documents are attached to and made a condition of this Bid:
  - A. Required Bid Security in the form of a Bid Bond, Cashier's Check, or Certified Check.
7. Communications concerning this Bid shall be addressed to the business address of BIDDER indicated herein.
8. The terms used in this Bid which are defined in the General Conditions of the Construction Contract included as part of the Contract Documents have the meanings assigned to them in the General Conditions.

SUBMITTED on \_\_\_\_\_, 20\_\_.

Bidder: \_\_\_\_\_  
 (Print or type full name of your proprietorship, partnership, corporation, or joint venture.\*)

\*\*By: \_\_\_\_\_  
 Signature Date

Name: \_\_\_\_\_  
 (Print or type name) Title

Address: \_\_\_\_\_  
 (Mailing)

\_\_\_\_\_  
(Street, if different)

Telephone and Fax Number: \_\_\_\_\_

(Print or type numbers)

- \* If Bid is a joint venture, add additional Bid Form signature sheets for each member of the joint venture.
  
- \*\* Bidder certifies that the only person or parties interested in this offer as principals are those named above. Bidder has not directly or indirectly entered into any agreement, participated in any collusion, or otherwise taken any action in restraint of free competitive bidding.

Note: This document constitutes a government record, as defined by § 37.01 of the Texas Penal Code. Submission of a false government record is punishable as provided in § 37.10 of the Texas Penal Code.

END OF SECTION

**NOTES:**

1. ACTUAL SHAPE OF CONCRETE TRENCH DAM CROSS SECTION MAY BE DETERMINED BY CONTRACTOR IN FIELD, MEETING MINIMUM THICKNESS AND KEY DEPTH REQUIREMENTS.
2. THIS DETAIL SHALL BE USED WITH CEMENT STABILIZED SAND EMBEDMENT, OR OTHER CLASS II EMBEDMENT, IN WET STABLE TRENCH CONDITIONS.
3. PLACE TRENCH DAMS IN CLASS I EMBEDMENTS AT THE MIDPOINT OF LINE SEGMENTS LONGER THAN 100 FEET BETWEEN MANHOLES.

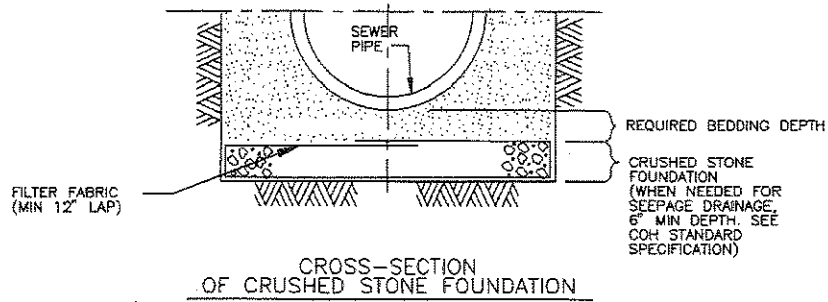

**CROSS-SECTION OF CRUSHED STONE FOUNDATION**

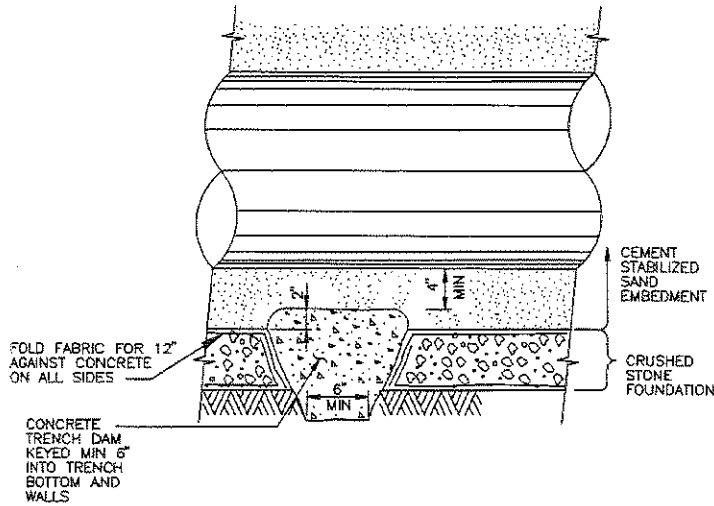

**LONGITUDINAL SECTION ALONG PIPE @ AT FOUNDATION TRENCH DAM**

DATE: \_\_\_\_\_ APPROVED BY: \_\_\_\_\_ DESIGN BY: \_\_\_\_\_

SCALE: **N.T.S.** DRAWING NO.: **S-107**

**CITY OF SEABROOK**  
DEPARTMENT OF PUBLIC WORKS

**SANITARY OR STORM SEWER  
CRUSHED STONE FOUNDATION  
FOR WET STABLE TRENCH**